

Direct current power for sustainable factories

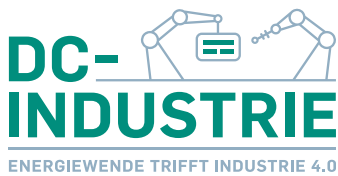



Direct current power for sustainable factories

Published by:

Research project DC-INDUSTRIE

Förderkennzeichen 03ET7558A-N; 03EI6002A-Q

c/o ZVEI - German Electrical and Electronic

Manufacturers' Association

Lyoner Strasse 9

60528 Frankfurt am Main, Germany

Responsible:

Gunther Koschnick

Phone: +49 69 6302-377

Email: automation@zvei.org

Authors of the ZVEI working group Communication DC-INDUSTRY:

Prof. Dr. Holger Borcharding (TH OWL), Erik Fosselmann (Danfoss GmbH),

Dr. Timm Kuhlmann (Fraunhofer IPA), Dr. Hartwig Stammberger

(Eaton Industries GmbH)

October 2020

The work, including all of its parts, is protected by copyright. Any use outside the strict limits of copyright law without the consent of the publisher is prohibited.

This applies in particular to reproduction, translation, microfilming and storage and processing in electronic systems.

Despite utmost care for the content no liability will be accepted.



In cooperation with:

ZVEI - German Electrical and Electronic
Manufacturers' Association

Automation Division

Lyoner Strasse 9

60528 Frankfurt am Main, Germany

Phone: +49 69 6302-0

Email: automation@zvei.org

www.zvei.org

Supported by:



Federal Ministry
for Economic Affairs
and Energy

on the basis of a decision
by the German Bundestag

In our daily lives, we have ever more devices that operate on direct current (DC), including mobile phones, LEDs, photovoltaic panels and more. Factories, too, are fast transitioning from alternating current (AC) to DC. DC-powered factories will soon be the new normal.

1 Why choose DC power?



The transition to renewables is one necessary step amongst many in the move to a more sustainable society. The goal is to lower human consumption of natural resources to a level that no longer exceeds the regenerative capability of the Earth. With regard to electrical power, this is only possible through greater efficiency and the use of zero-carbon renewable energy sources. At the same time, manufacturing must become more digital, integrated and personalised/customised. The increase in the use of electronics as well as many sensitive production processes call for maximum security of electricity supply. Germany's existing power grid is 130 years old, and not fit for this purpose. With this in mind, the supply of electricity to industry must be transformed.

This position paper is aimed at stakeholders in industry, research and politics. The goal is to provide them with insights into the concept of a manufacturer-agnostic, open direct current (DC) grid as the basis for resolving the challenges associated with industrial power supply.

The positive power of DC

The more than 40 partners who participated in the DC-INDUSTRIE and DC-INDUSTRIE 2 projects, funded by the Federal Ministry for Economic Affairs and Energy (BMWi) since 2016, have jointly defined and investigated the fundamental characteristics of DC infrastructure for industry, and identified the following:

1. Lower feed-in power

It proved possible to reduce the grid feed-in power supplied via a local DC grid to a robotic welding cell in the automotive industry from 450 kW to 50 kW. This was enabled by the seamless integration of high-speed energy storage devices.

2. Increased energy efficiency

A reduction in the number of AC-DC/DC-AC power converters and their associated power losses, and the recovery of braking energy from moving masses, led to energy savings of between 6 and 10 per cent, depending on process dynamics.

3. Standardisation is already far advanced

The significant involvement of leading industrial players and the transfer of insights from the DC-INDUSTRIE research project to national and international standardisation bodies will ensure the long-term success of DC grids.

4. Robust, fail-safe power supply

Local DC grid management, featuring a number of basic functions but not requiring a dedicated communications infrastructure, the simple integration of energy storage, and connection to the public AC grid ensure a reliable, secure energy supply.

5. DC grids are safe

Local DC grids are as safe as the legacy nationwide AC grid. Corresponding protection devices safeguard people and equipment during operation and in the event of faults.

6. A DC grid is a smart grid

Predefined voltage droop curves in devices enable the continuous, immediate alignment of power demand with supply. An overarching power management system to optimise the cost- and energy-efficiency of the DC grid can be easily integrated.

7. Easy integration of renewables

As solar energy generation systems supply direct current, there is only a need for a DC-DC converter and not for a far more complex inverter. This not only saves money, it also makes the system more dynamic and improves energy efficiency..

8. Grid-friendliness

A DC grid can support the AC grid. For instance, storage devices connected to the DC grid can receive and store power from or feed power into the AC grid. This makes it possible to better manage fluctuations and imbalances in supply and demand.

9. Smaller, lighter, cheaper

The converters needed for energy-efficient drives will become simpler, smaller, and more affordable. Many of the components required for AC will not be necessary for DC. Converters can be reduced in size by up to 25 percent. Similar size reductions will be possible for other electronic devices connected to the DC grid.

Direct current power supply works. DC grids were implemented for four realistic pilot production systems. The systems operated smoothly, without faults – and with lower electricity consumption.

2 How does a DC grid help?

Background

The DC-INDUSTRIE project was primarily initiated by the German Electrical and Electronic Manufacturers' Association (ZVEI) Section Electric Drive Systems. The motivation is described below.

70 per cent of all electricity consumed in manufacturing is attributable to electric motors. This makes them by far the largest single consumer of electrical energy. Any reduction in the power consumption of these drives through greater efficiency also means correspondingly lower carbon emissions. From 2021, all AC motors sold in the EU in the power range 0.75 to 375 kW must comply with the requirements of energy efficiency class IE3. Energy efficiency classes are defined for each electric motor operating at its nominal speed (r.p.m.) and nominal torque, i.e. for an operating state that is not typically relevant for real-world usage. This increases the cost of and resources used for their manufacture but without achieving the desired reduction in electricity consumption.

A proven approach to achieving far greater energy efficiency is the use of variable-speed motors. Efficiency can also be improved by deploying frequency converters in the three-phase power supply, however conventional converters have a number of negative features. They are therefore an obstacle to even greater energy efficiency and impact the AC grid by disrupting sinusoidal voltage. Figure 1 depicts the configuration and disadvantages of AC-to-AC converters.

Figure 1: Current situation with AC-to-AC converters

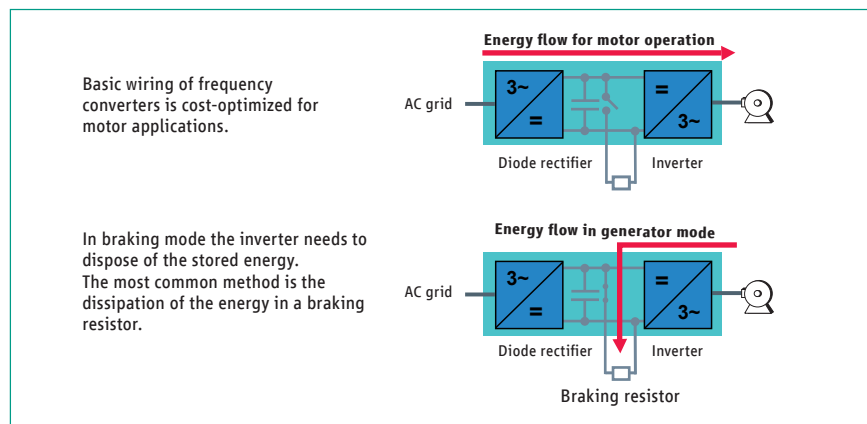

Source: TH OWL

Since AC-AC converters operate internally on DC voltage, it makes sense to connect this DC voltage directly to the DC grid to avoid unnecessary conversion losses (from the additional DC to AC conversion), as shown in Figure 2. This allows a large proportion of braking energy to be made available for immediate use by other devices.

Figure 2: Electrical energy exchange via a DC grid

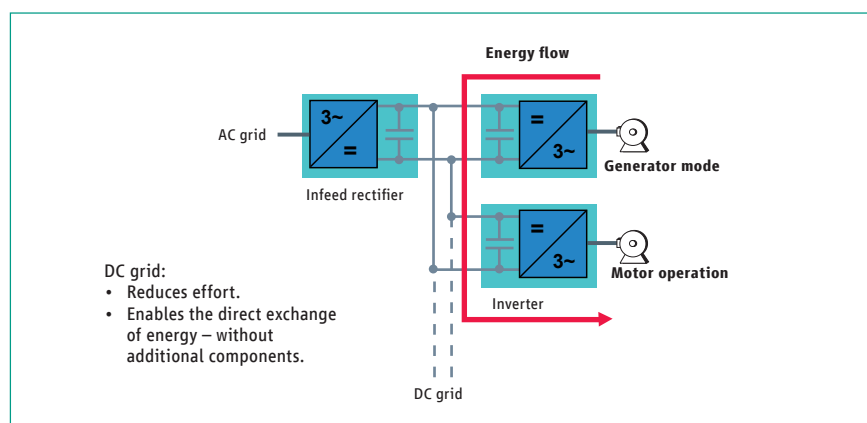

Source: TH OWL

Against this background, manufacturers of electrical drive systems were the first to put their weight behind the DC-INDUSTRIE initiative. An integrated, system-wide approach that is open to DC grids, manufacturer-agnostic and suitable for wide deployment within industry also offers further advantages. This explains why many companies are interested in DC grids. These advantages are described below.

The cost advantages of an integrated system-wide approach

It can be assumed that the integrated, system-wide approach to DC grids will lower the cost of equipment and of ongoing operation. For example, frequency converters require fewer components within a DC grid. Moreover, there are savings with cabling. There is also potential for investment cost reductions for the incoming AC power supply unit, as installed power can be lowered within a DC grid. However, certain aspects of DC grids will generate higher costs, for example for protection devices. But these are outweighed by the additional functions/capabilities.

For example, the power electronics deployed in DC grid devices are able to control power efficiently and to monitor the state of the grid via internal sensors. This makes factories more sustainable, and supports their digital transformation. The visibility this grants into electrical power flows opens up further opportunities far beyond energy savings. For instance, anomalous flow patterns can be analysed to detect equipment wear-and-tear at an early stage, and to take action to prevent unplanned downtime.

Independent microgrids

A DC grid within a factory is an independent microgrid that is connected to the larger public grid. The combination of direct current and independence allows the low-cost and simple integration of storage systems (such as batteries) and local power generation plants into the factory's electrical supply system. If there is disruption to the supply of electricity, for example short-term interruptions, the microgrid can be decoupled from the public grid and can continue to supply power to production equipment. If there is not sufficient local power to maintain production during prolonged supply outages, then it is at least possible to cease production processes in a targeted, controlled way. When the power supply returns, it is possible to resume production without the need for lengthy recovery/start-up procedures, minimising downtime. And it is furthermore possible to avoid the scrap that would result from sudden, uncontrolled halting of production equipment.

Optimisation through an integrated, system-wide approach

Industrial DC grids are emerging as important tools in the transition to renewables. An end-to-end system-wide approach that considers how all components and applications within a factory interact, and the integration of generation, storage and consumption, opens up further opportunities for greater energy efficiency both for individual devices and in terms of their interaction as a system. Functions that individual devices either cannot support, or can only support with significant effort and expense, can be performed by multiple devices interacting at system level, in the form of services delivered by the factory microgrid. This includes, as mentioned above, the ability to overcome short-term supply outages, but also the ability to lower the costs of operating a microgrid by, for instance, reducing peak load or atypical grid usage. Over time, a factory microgrid becomes increasingly "friendly" to the public grid, and therefore helps to safeguard security of supply at a higher level and on a broader basis.

There is also synergy with the adoption of electric vehicles (EVs), as these run on direct current. Connected EVs can be used to store power that can then be consumed by the factory in the event of short-term interruptions in supply – without the need for conversion via the AC grid and the associated losses. Additionally, the microgrid can manage the charging of connected EVs in a way that avoids additional and expensive peaks in load and makes the best possible use of locally generated green power.

*Yes, DC grids are coming.
And DC-INDUSTRIE is preparing the ground.*

3 DC-INDUSTRIE – put simply

DC-INDUSTRIE has defined specifications for an open, simple power supply system for users and device manufacturers that supports rapid implementation.

DC-INDUSTRIE is preparing an infrastructure for a smart DC factory supply grid with the goal of achieving the most important advantages of Industry 4.0, such as extensibility, the availability of richer information, and self-organisation, within the context of production processes.

This infrastructure enables high energy efficiency, easy integration of renewable energy sources, flexible energy management, and high availability for users.

The operating voltage is between 485 V and 750 V, depending on the type of voltage control (active or passive). Within this range, it is possible to make widespread use of standard technologies and components. Where voltage exceeds the upper threshold of 800 V or falls below the lower threshold of 400 V, the grid is deactivated.

The active components within the DC grid continuously match power supply to demand. To this end, voltage is measured regularly and compared with a voltage droop curve. Where there is a surplus of electrical power, voltage increases and power is placed into storage systems. When power demand increases (and voltage falls), these storage systems are leveraged as sources of energy. These droop curves can also be utilized to prioritize certain power-consuming devices. For example, critical applications can be given priority across the entire voltage range, while less important consumers can be deactivated where power supply is low.

Figure 3 provides an overview of an industrial DC grid that was implemented within the scope of the DC-INDUSTRIE project. All components are interconnected via the DC grid and can therefore directly exchange electrical power. The DC grid itself is connected to the AC supply grid via a single bidirectional inverter/rectifier (an active infeed converter, AIC, sometimes also called an active front end, AFE). Energy use is actively managed in real time – although this is not essential for operation of the grid.

Storage components, such as capacitors, batteries and flywheel energy storage (FES), can provide power to overcome disruptions in supply, such as AC grid outages. They can all be employed to “shave” peaks in power supply, and to lower the factory’s feed-in power.

Figure 3: An industrial DC grid with integration of renewables and energy storage

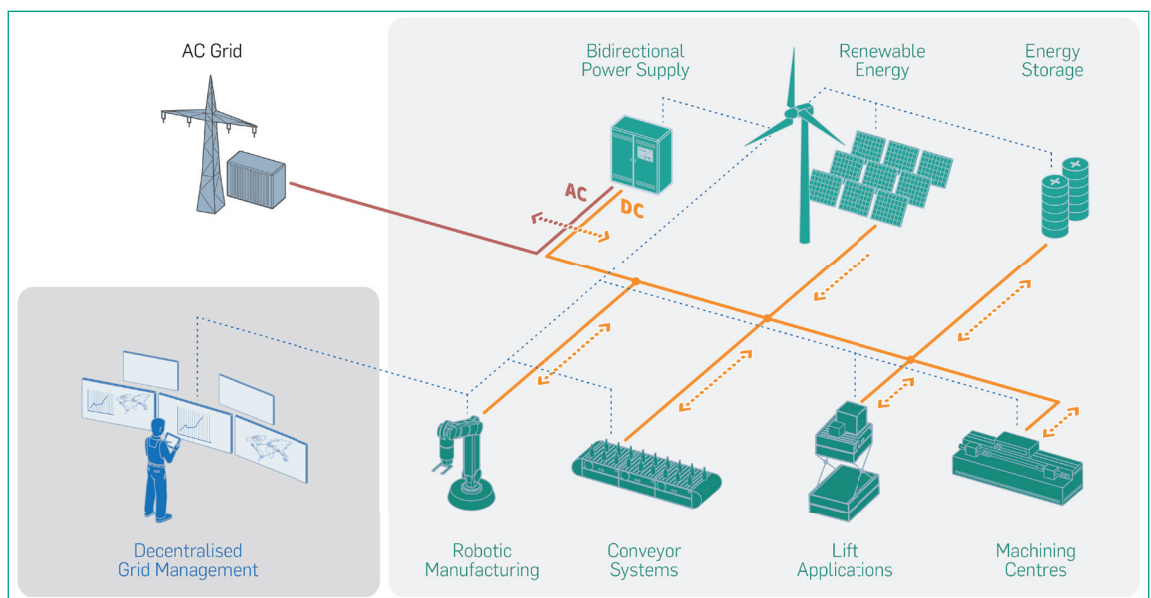

Source: ZVEI

4 What has been achieved to date?

Within the scope of the DC-INDUSTRIE research project, four pilot but technically realistic production systems were fitted with DC components from diverse manufacturers and successfully put into operation. Power was supplied entirely by direct current. Electric drives, e.g. for robots and power-hungry applications such as welding, were incorporated, as were energy storage systems.

1. A variety of tests were performed that demonstrated each pilot system operated smoothly and without faults. With one system it proved possible to reduce feed-in power by 85 per cent.

In addition to lower costs for DC devices, e.g. for purchasing voltage converters that are approximately a quarter smaller than their AC equivalents, there were savings in the fees charged by utilities for guaranteed peak feed-in power. The aggregate saving in terms of energy consumption was between 6 and 8 per cent for all DC-connected applications.

2. For manufacturing companies, the reduction in production downtime caused by power supply disruptions is of even greater significance than energy savings. The storage systems are easy to integrate and provide sufficient power to place machines and robots into a predefined start position. When the power supply returns, production can therefore be resumed very quickly.
3. In addition to energy savings, it is possible to conserve natural resources. A DC cable, for example, requires some 40 per cent less copper than an AC cable – as the number of conductor cores is cut from five to just three. Moreover, up to 25 per cent less insulation material is needed. This leads to a reduction in the carbon released during manufacture of up to 38 kg per kilometre of cable.

By eliminating multiple converters in the drive control units and by lowering central feed-in power, it is also possible to eliminate a number of other electronic components. This means a further reduction in the carbon footprint per machining centre of 100 kg.

Visitors to the 2019 Hanover industrial fair (Hannover Messe) were able to experience the DC system implemented by the DC-INDUSTRIE project in operation. Two industrial robots supplied with DC power realistically simulated the welding of a component, as shown in Figure 4.

Figure 4: DC-powered industrial robots at the DC-INDUSTRIE stand at the 2019 Hanover industrial fair

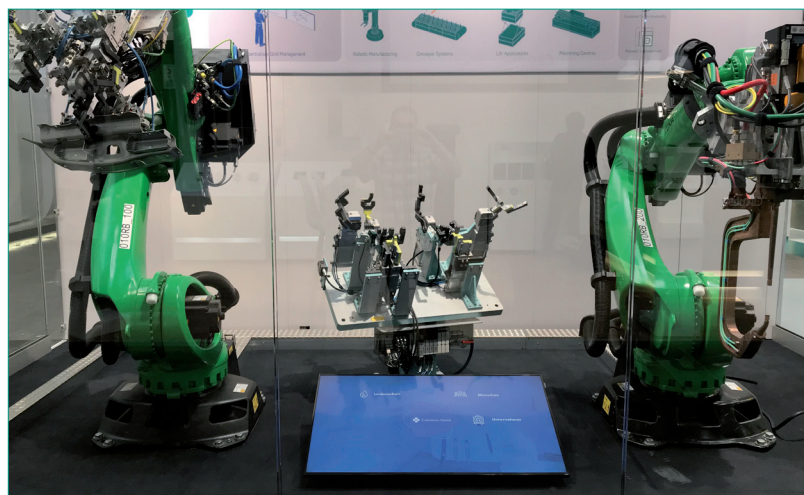

Source: DC-INDUSTRIE

5 What future developments can be expected with DC grids?

The results to date of the DC-INDUSTRIE project were published in German by Hanser Verlag in 2020 in a book entitled *Die Gleichstromfabrik* (The Direct Current Factory, English version to follow). It is intended to provide in-depth information on industrial DC technology for decision-makers and specialists.

The DC-INDUSTRIE 2 project builds upon the achievements of DC-INDUSTRIE. Its focus is on enhancing DC grids to create smart DC grids for factories and other large-scale industrial facilities. It will additionally seek to improve the connection to the AC supply grid in a way that ensures production can be maintained at all times and maximum use can be made of renewables, despite their intermittent nature, and that the power generated can also be fed into the AC grid. These capabilities are collectively known as “grid friendliness”.

In particular, this follow-up project will work on:

- Further development of installation, protection and device technology,
- Enhanced interaction between the various production systems / infrastructure components,
- Development of project management tools and methods, and
- Minimisation of any negative impact on the AC grid

The overall aim of these activities is to make the major benefits of smart DC grids with regard to energy efficiency, resource conservation, production uptime and grid friendliness more rapidly available.

Additionally, there are plans to help the broader community of technical experts to make better use of DC technologies by means of DC-INDUSTRIE knowledge transfer/training centres. These centres will feature model systems at universities and research organisations where attendees will have the opportunity to experience the advantages of DC grids in person and “hands on”. These centres will, in particular, address issues related to health and safety. In this respect, the same regulations and requirements apply to DC as to AC. Health and safety are based on five key rules described, for instance, in DIN VDE 0105-100 and IEC 60364, for both AC and DC. In other words, there are already rules in place that govern safety in DC environments. However, there is a need for further training in DC technology for electricians and electrical engineers in order to overcome reservations associated with the current lack of experience with low-voltage DC grids. DC-INDUSTRIE knowledge transfer centres can play a part in this endeavour by offering an easily accessible resource.

Market availability of DC grid components:

- Existing frequency converters used with the AC grid require only minor modification in order to operate within DC grids.
- DC cables are already commercially available.
- Viable solutions and extensive experience for protection mechanisms and switching are already familiar in fields such as photovoltaic power and railway technology.
- Active infeed controllers are already known from solar energy farms and arrays of multiple drives. They require only slight modification for local DC grids. In the future, further developments will become available for increasing efficiency and for the provision of value-added services, such as filtering.

6 Further information and links

- DC-INDUSTRIE online: www.dc-industrie.de (in German)
- Interactive presentation at 2019 Hanover industrial fair:
<https://experience.dc-industrie.zvei.org/>
- Presentation on the results of DC-INDUSTRIE:
https://dc-industrie.zvei.org/fileadmin/DC-Industrie/Praesentationen/180202_DC-INDUSTRIE_DC_grid_concept_A04w.pdf
- Presentation on DC-INDUSTRIE 2:
https://dc-industrie.zvei.org/fileadmin/DC-Industrie/Praesentationen/DCI2_Project-presentation_en.pdf
- German Electrical and Electronic Manufacturers' Association (ZVEI):
<https://www.zvei.org/en/>
- YouTube Series "Watts on" on DC by ZVEI (in German):
<https://www.youtube.com/watch?v=CnROw7eNFAA>
- Die Gleichstromfabrik book published by Hanser Verlag (in German, English version to follow):
<https://www.hanser-fachbuch.de/buch/Die+Gleichstromfabrik/9783446465817>



Source: Sauer, Gleichstromfabrik © 2020 Carl Hanser Verlag München

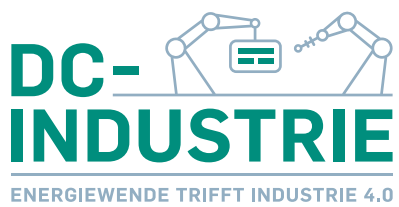

Research project DC-INDUSTRIE
c/o ZVEI - German Electrical and
Electronic Manufacturers' Association.
Lyoner Straße 9
60528 Frankfurt am Main, Germany
Phoe: +49 69 6302-0
Fax: +49 69 6302-317
Email: zvei@zvei.org
www.zvei.org